

FIVE WAYS TO AVOID A CATCH

Demystifying the demon

LYLE JAMIESON

IN RECENT ISSUES OF *AMERICAN WOODTURNER*, I have noticed that people regularly mention catches, as if they are commonplace happenings that seem to have a life of their own, popping up at the most inopportune time. *Catch*...what a paralyzing thought to take to the lathe with you! It must stifle much creative spirit. Does it stand between you and a thin-walled vessel? Is it really so unpredictable and uncontrollable? I think not!

During a demonstration at my local club meeting several months ago, I was cleaning up the bottom of the piece and working very close to a glue block. The corner of my bowl gouge caught the waste block ever so lightly and the telltale sound of a catch echoed out into the audience. I heard from the corner of the room, "AH HA! Even the demonstrator gets a catch." This was not entirely true. The piece I was working on was not damaged, the gouge was not even in contact with it. I got the catch on the waste block. True it was an error on my part and it could have been disastrous. But I was watching the bottom of my bowl, not the waste block. This is a much different experience than the surprise and shock of a catch inside a bowl.

Catches are not commonplace for me. They are rare and I know what I did when I've caused one. They do not sneak up on me like mysterious demons. In this article I hope to show how and why catches happen, what it is that sucks your tool into the wood when you get a catch, and how to avoid it.

Let's first define some terms. I am sure you have heard that we need to turn "with the grain," or "downhill." What does that mean? On a spindle, where the grain is parallel to the lathe axis, it is easy to see that "downhill" means cutting toward

that axis. As the arrows show in Figure 1, each fiber of wood being cut

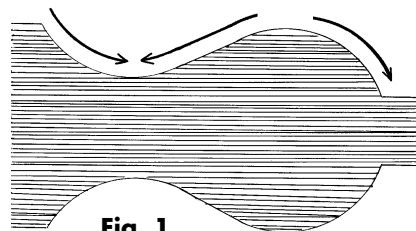

Fig. 1

(sheered or scraped) is supported by the fiber just below the one being cut.

In a bowl we have grain going perpendicular to the lathe axis, just the opposite of spindle turning. A cross section of the work (Figure 2) indicates that the direction of a downhill cut depends on whether it's on the inside or outside of the bowl. But we can cut "downhill" till the cows come home and still get a catch. I will show why.

In cutting, you move along a plane while the wood is moving around an axis. The force of the wood rotating against the tool on the tool rest is much more significant than the force you produce by pushing the tool along the plane. As the bowl rotates, twice in every rotation, it encounters both side grain and end grain, and in between you are cutting alternately with and against the grain. As you leave the side grain and approach the end grain, you are cutting "uphill" twice every rotation, and that creates the possibility of a catch (Figure 3). You can visualize now why your tool wants to get sucked into that end grain, and a catch happens.

I will discuss five methods to minimize the risk of catches: 1) use sharp tools, 2) ride or follow the bevel, 3)

use a 45-degree shear whenever possible, 4) support your tools on the tool rest, and 5) position your tool properly in hollow forms.

First, a sharp tool can shear off those end-grain fibers cleanly and smoothly, while a dull tool will push, grab, and tear them out. You can do all the right techniques and still have trouble with catches if your tools are not sharpened properly. It is well worth the time and effort to make a grinder with an 8-inch aluminum oxide stone and a low-rpm set-up. I have an old 1/4-hp motor and a pillow block and shaft. The pulleys allow me to gear the grinding wheel down to about 900 rpm. The slow speed allows me to grind more accurately.

Secondly, I think most catches come from allowing the turning tool to cut while it's not being supported by the bevel. Consider where you're most likely to encounter a catch: on the inside of a bowl—because that's where you're most likely to have loose bevel contact. How do you make sure you maintain bevel contact? Try to visualize the heel of the bevel as you turn, and the edge will take care of itself. Ride the bevel. If no cut happens, no harm is done. But if you cut and don't have the support of the bevel, you flirt with a catch, even using sharp tools. Notice in Fig-

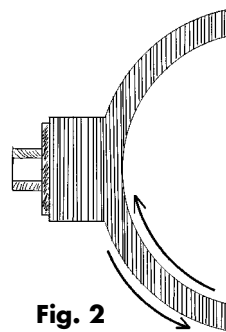

Fig. 2

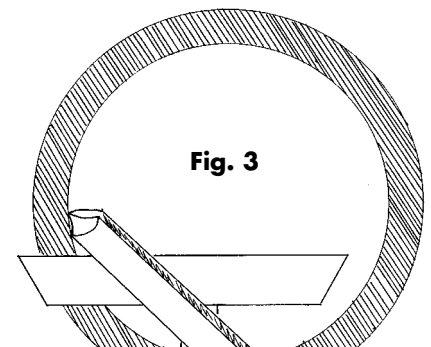

Fig. 3

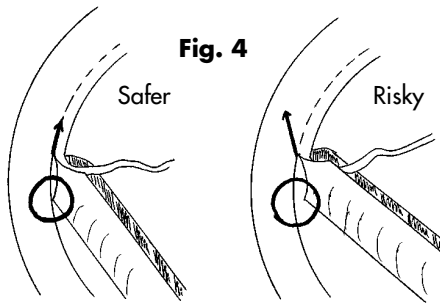

Figure 4 the natural path the cutting edge would take while riding the bevel. It is not necessary to use any pressure to ride the bevel. You don't want to burnish the wood with the heel; in fact, in a piece with voids or a natural-edge where there is no wood to ride, the bevel must follow the path where the wood would be.

The third aid to prevent catches is to maintain a 45-degree sheering cut with your tool. How do you shear end grain? Take a trip back memory lane to junior high shop class and your first bird house. You probably took a hand plane and tried to clean up the end grain of a block of wood. The plane chattered, gouging and chipping the board until your instructor showed you how get a clean cut by angling the plane blade 45 degrees to the direction of travel on the board. If you present the cutting edge of your bowl gouge at a 45-degree angle to the radial movement of your work, you will get the same clean slice while turning that intermittently present end grain.

Try this first on the outside of your bowl, or watch the process on a spindle turning. On the inside of a bowl you point the flute in the direction of the cut. Stay in the middle third of your gouge's cutting edge. This tilt will yield a 45-degree sheering cut. The approach works well while following the bevel of a bowl gouge. It also works with a scraper to produce a sheer-scraping cut.

Another force at work in a catch is the force of the cut down on the tool rest. The edge of a 12-inch bowl rotating at 1,000 rpm is traveling 52 feet per second, or 36 miles per hour. That's a great deal of force on the tool. (This might be a good time to mention sharp tools again. With all

the dynamic forces involved the sharper the tool, the easier the tool passes through the wood fibers.) The fourth aid to prevent catches is to make sure the cutting edge of your gouge is directly supported by the tool rest. If your cutting edge gets way out on the wing or corner of the gouge there is no support by the tool rest. In Figure 5 the arrows represent the force of the wood as it spins by the tool. When the end grain of the bowl comes around to grab your

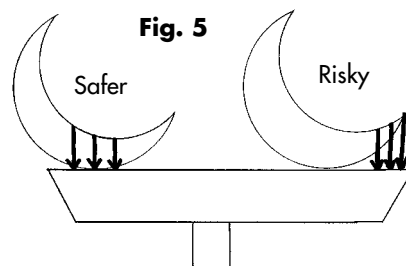

gouge, the space below the cutting edge could allow the gouge to twist in your hand—the genesis of a catch.

Finally, the fifth aid concerns catches that happen while using scraping tools inside hollow forms. The position of the cutting edge on the radial axis is very important. As Figure 6 indicates, if your cutting edge is slightly above the centerline when you start to get a catch, the force of a catch will pull your tool away from the wood. When your

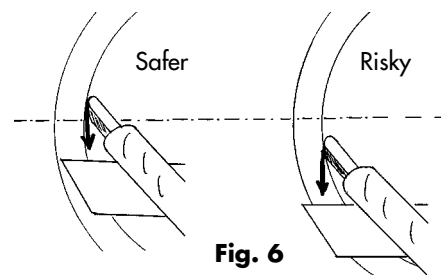

tool is below center and a catch starts, the cutting force downward on the tool rest will dig the cutting edge deeper into the wood.

Another hazard in deep hollow turning occurs when the cutting edge of your tool is higher than the han-

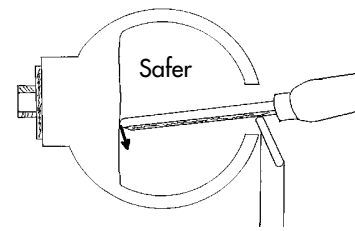
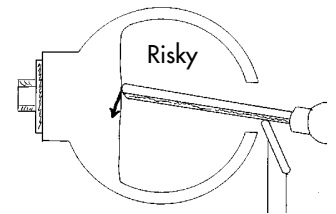

Fig. 7



dle. Handle down is the standard position when using a bowl gouge, but not while cutting across the bottom on the inside of a hollow form. With the cutting edge tipped up into the grain, if a catch starts, the force is directed deeper into the wood. (Ouch!) With the handle up, as in Figure 7, the chatter from grain irregularities that might start a catch will force the tool away from the wood.

Another tool positioning aid to prevent catches is to rotate your cutting edge a little counter-clockwise from horizontal. This twisted position will prevent the edge of the tool

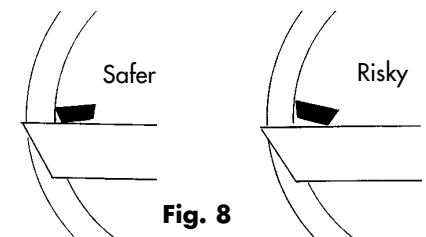

Fig. 8

from digging into the grain and starting a catch. Figure 8 is a view looking down the shaft of the tool into a deep hollow turning.

So now we have five ways to stay away from catches: 1) use sharp tools, 2) ride or follow the bevel, 3) shear at a 45-degree angle, 4) have tool-rest support, and 5) maintain a safer tool position. It is not always possible or necessary to do all five. Losing the support of the bevel is the problem that causes most catches. If you are in a tight spot and you can't ride the bevel, observing the other four rules will help prevent catches.

Lyle Jamieson, of Traverse City, MI, has been turning since he was sixteen.