

<b>Jean Michel</b>	TITRE threader feeder mount 11.dwg	DESSIN PAR jm	ECHELLE SCALE 1" = 4"
	PROJ Wood Threader for boxes	NO: wt001 DATE: 02-06-30	FEUILLE PAGE 1/6

# Jean Michel

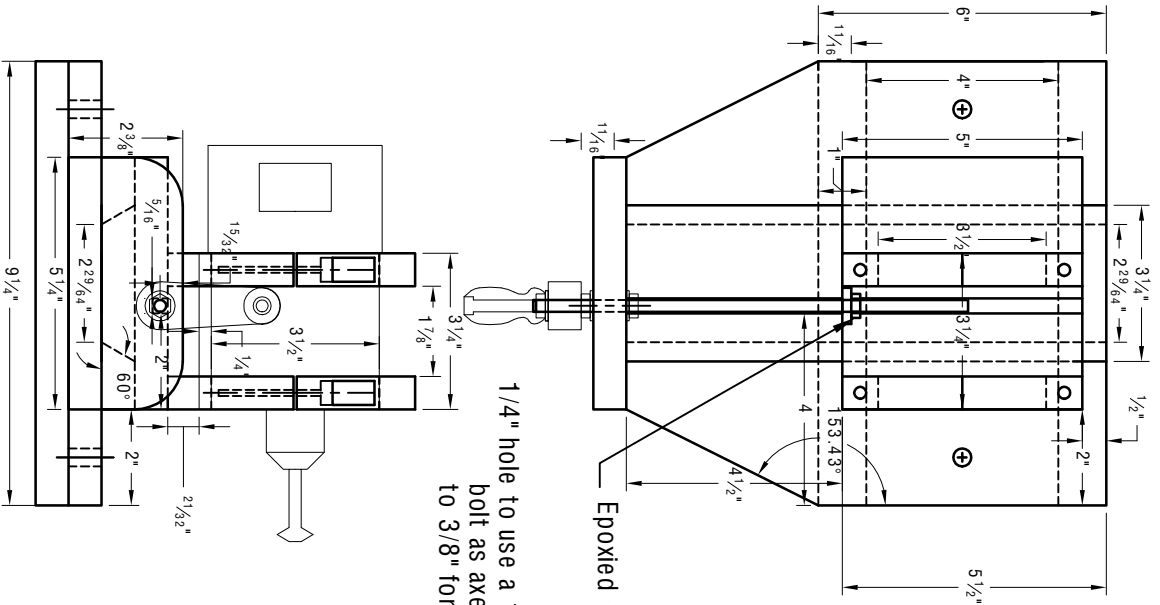

Epoxied 1/4" 20TPI nut

1/4" hole to use a 1/4" 20TPI bolt as axel enlarged to 3/8" for bolt head

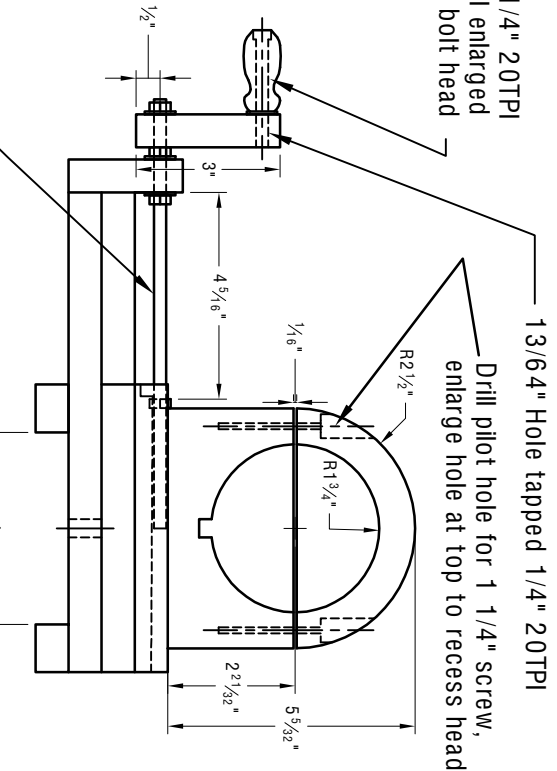

1/3/64" Hole tapped 1/4" 20TPI

Drill pilot hole for 1 1/4" screw, enlarge hole at top to recess head

1/4" 20TPI threaded rod ± 9"

TITRE	threader feeder mount 11.dwg	DESSIN PAR	jm	ECHELLE	1" = 4"
PROJET	Wood Threader for boxes	DATE:	02-06-30	FEUILLE	2/6
	NO: w1001	DRAWN BY		SCALE	

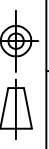

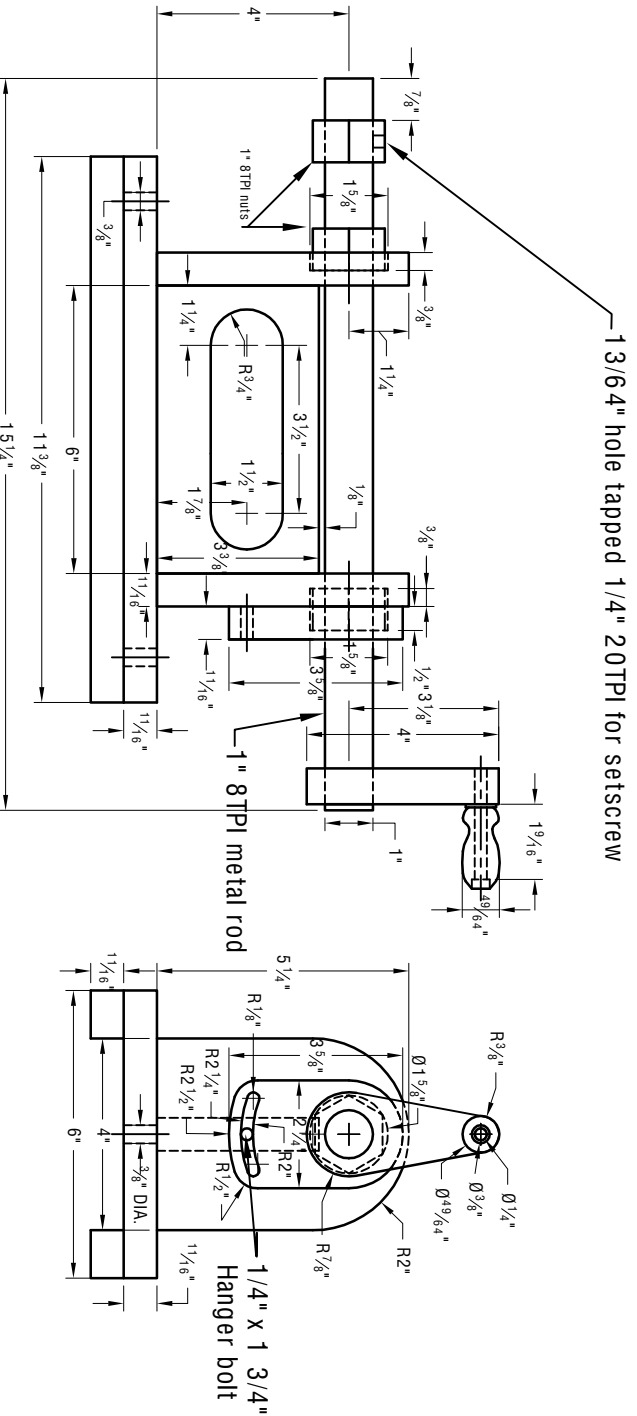

# Jean Michel

TITRE	threader feeder mount 11.dwg	DESIGN BY	jm	ECHELLE	1" = 4"
PROJET	Wood Threader for boxes	DATE:	02-06-30	FEUILLE	3/6
	NO: w1001				

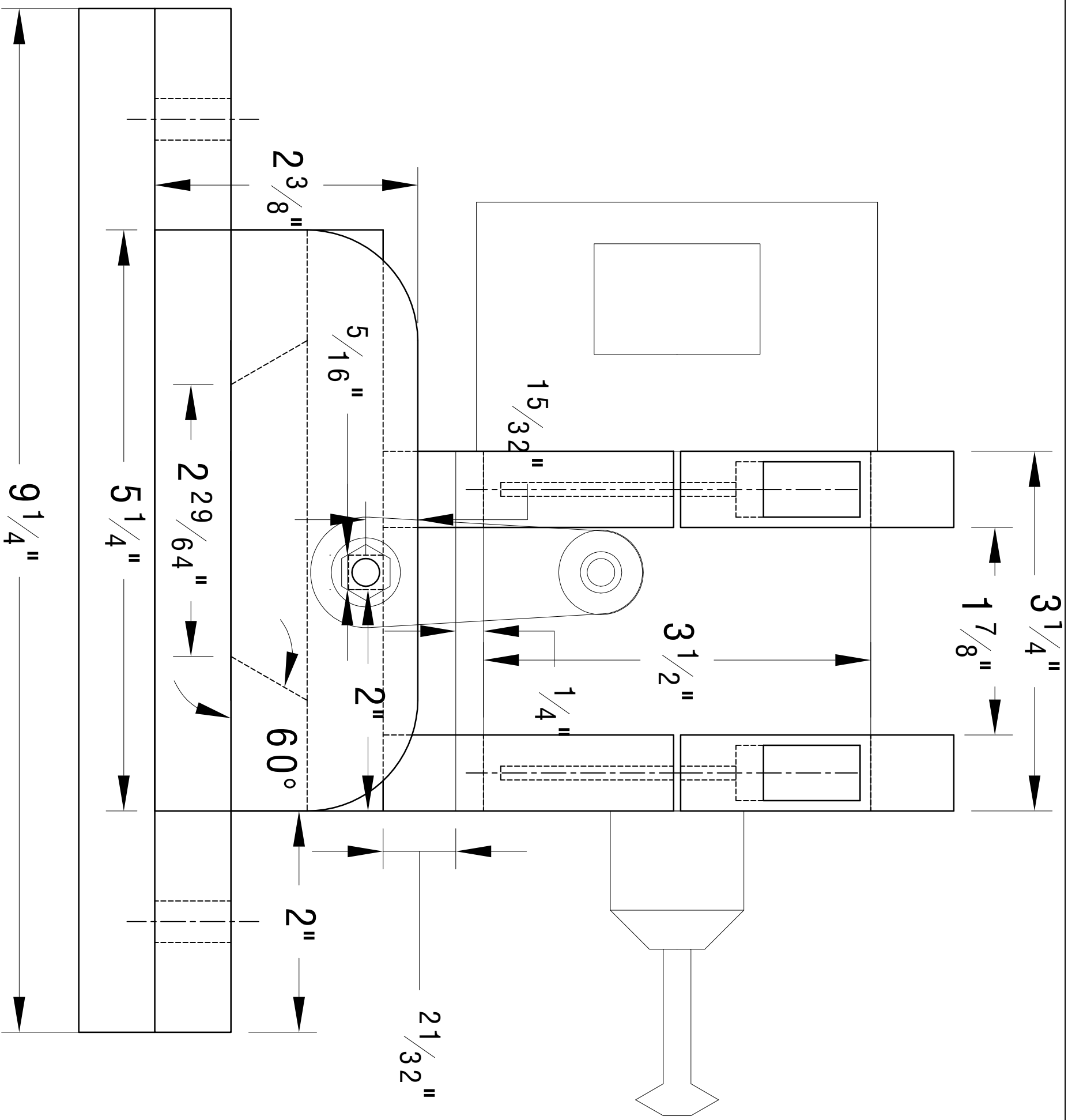

Jean Michel

MATERIAL	Baltic Birch ply	FILE	threader feeder mount 11.dwg
TOUTES LES DIMENSIONS SONT EN POUCES All dimensions are in inches		PROJET	Wood Threader for Boxes
FINI		CLIENT	Woodturning Community
PIECE NO:		NO: w001	
PART NO:		PROJECT	
DESSIN PAR jm		DATE: 02-06-30	
APPROUVE PAR jm		DATE:	
NO:		FEUILLE 4/6	
SCH: 1" = 1"		PAGE	

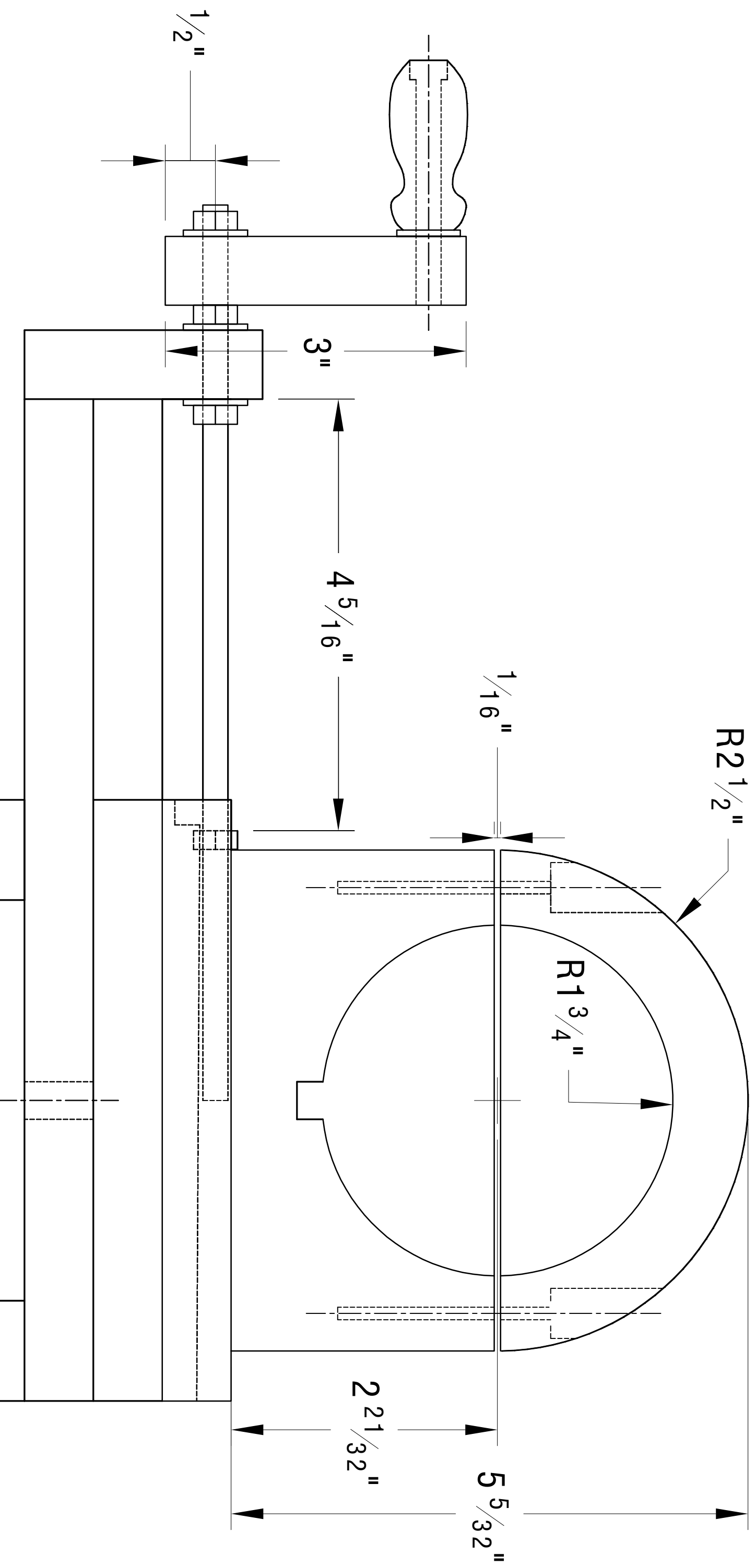

Jean Michel

MATERIAL	Baltic Birch Ply	FILE	threader feeder mount 11.dwg
TOUTES LES DIMENSIONS SONT EN POUCES All dimensions are in inches		PROJET	Wood Threader for Boxes
FINI		CLIENT	Woodturning community
PIECE NO:		DESSIN PAR	jm
PART NO:		DATE:	02-06-30
		APPROUVE PAR	jm
		DATE:	
DIM:	11" x 17"	NO:	
SCH:	1" = 1"	FEUILLE	5/6
		PAGE	

3 6"

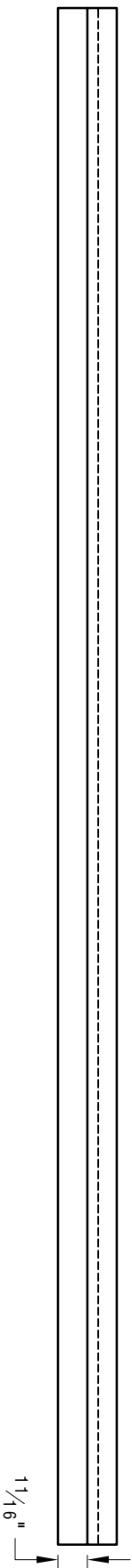
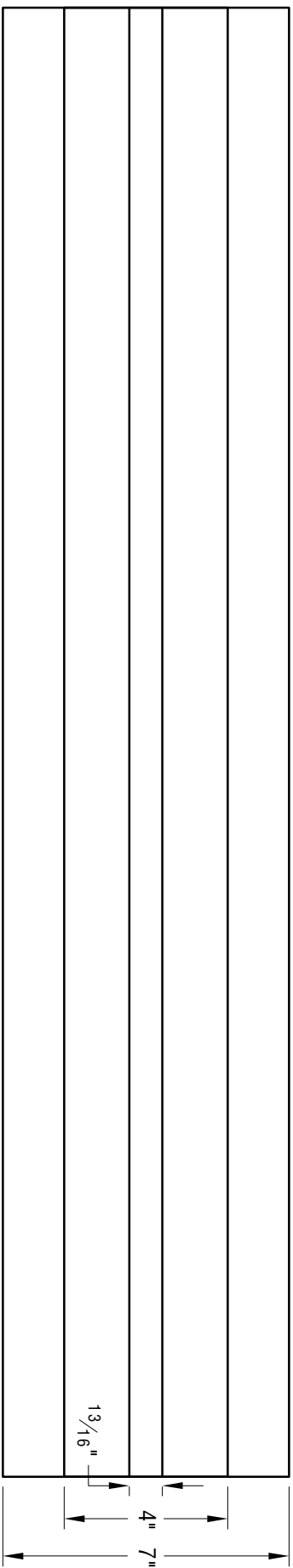

Mounting bed for wood threading jig  
Baltic birch plywood 18mm (sold for 3/4")

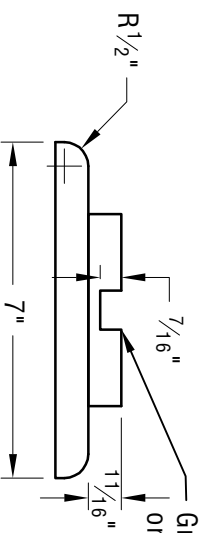

Groove to receive B-line B-72 Mini-channel  
or any much more expensive T type track!

Jean Michel

TITRE	threader feeder mount 11.dwg	DESSIN PAR	jm	ECHELLE	1" = 4"
TITLE		DRAWN BY		SCALE	
PROJET	Wood Threader for boxes	DATE:	02-06-30	FEUILLE	6/6
PROJCT				PAGE	
	NO: w001				



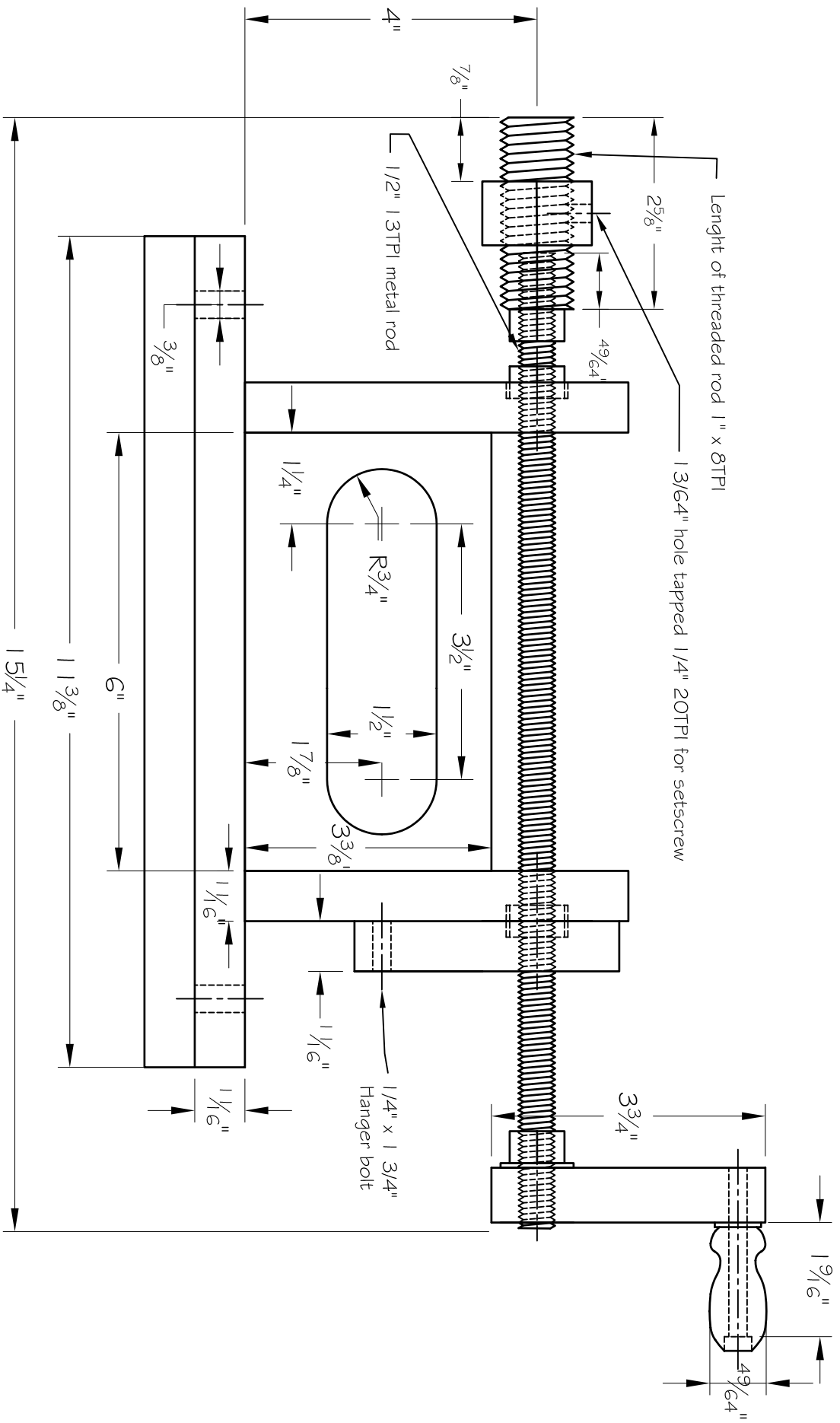

Jean Michel

TITRE	threader feeder mount 11.dwg	DESSIN PAR	jim	ECHELLE	1" = 2"
TITLE		DATE:	02-06-30	SCALE	
PROJET	Wood Threader for boxes	NO:	w001	FUILLE	3/6







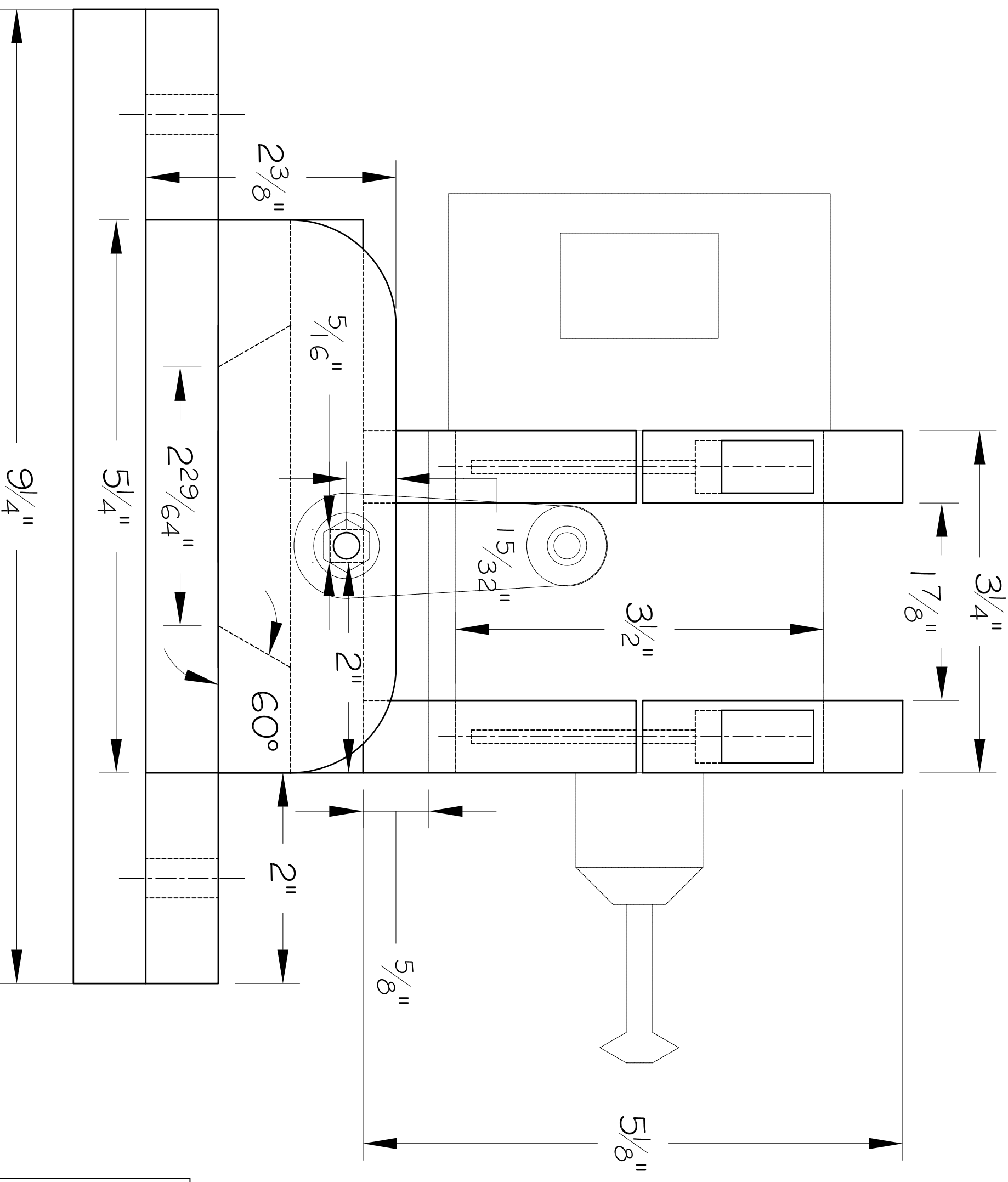

Jean Michel

MATERIEL Baltic Birch ply		111111m threader feeder mount 11.dwg	
TOUTES LES DIMENSIONS SONT EN POUCES All dimensions are in inches		NO: w1001	
PROJET Wood Threader for boxes		NO: w1001	
CLIENT Woodturning Community		NO: w1001	
PIECE NO:		NO: w1001	
DESSIN PAR jim		DATE: 02-06-30	
DRAWE PAR jim		DATE:	
APPROUVE PAR jim		DATE:	
NO:		FEUILLE 4/6	
ECH: 1" = 1"		PAGE 4/6	

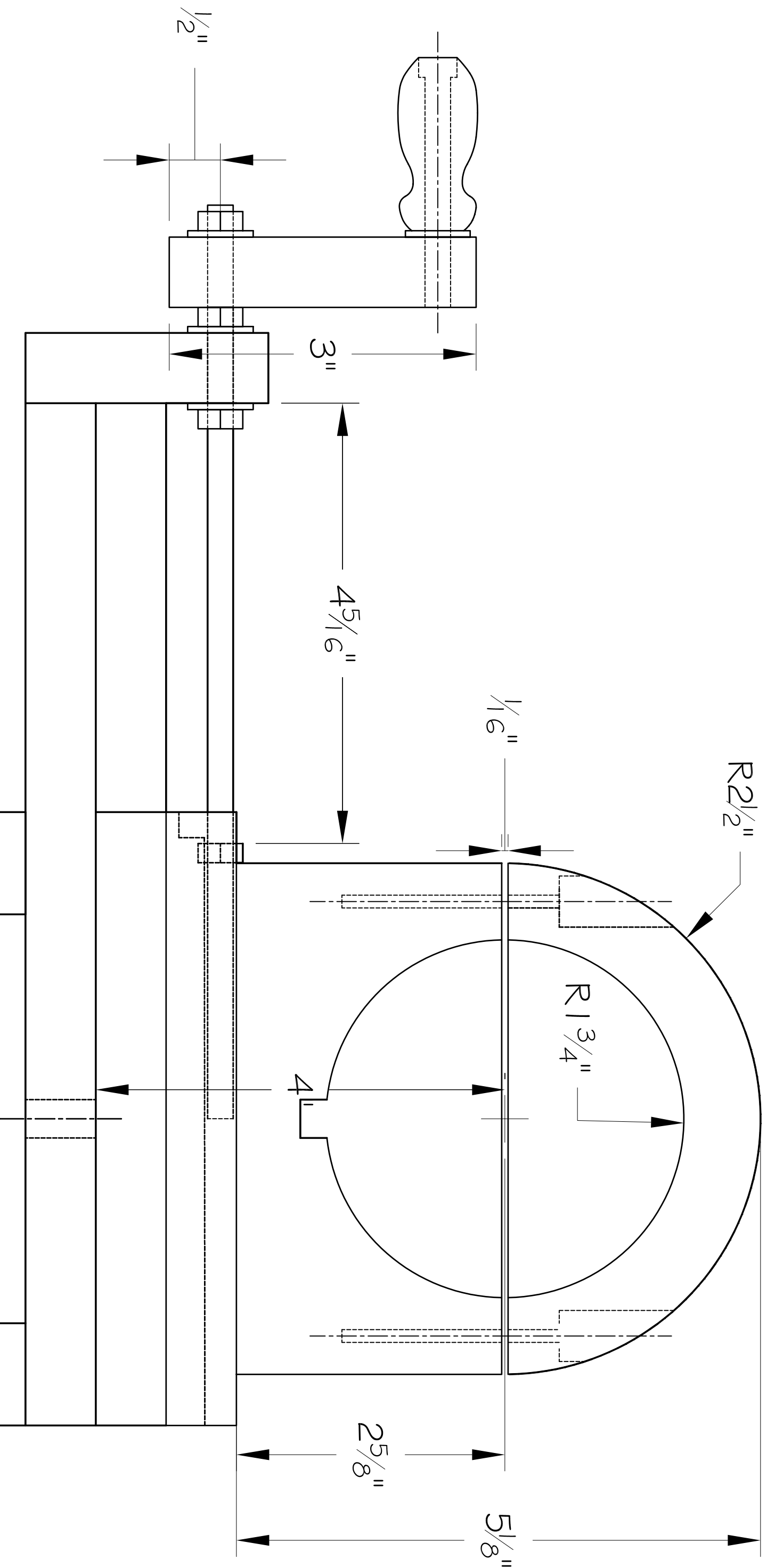

Jean Michel

MATERIEL Baltic Birch Ply  
 MATÉRIEL Baltic Birch Ply

TOUTES LES DIMENSIONS SONT EN POUÇES  
 ALL DIMENSIONS ARE IN INCHES

PROJET Wood Threader for boxes  
 PROJETS Wood Threader for boxes

CLIENT Woodturning community  
 CLIENT Woodturning community

PIECE NO:  
 PART NO:

DESSIN PAR jm  
 DRAWN BY jm

DATE: 02-06-30  
 DATE:

APPROUVE PAR jm  
 APPROVED BY jm

NO:  
 NO:

FEUILLE 5/6  
 PAGE 5/6

1" = 1"

1" x 17"

1"

4"

5/8"

25/8"

4"

R1 3/4"

R2 1/2"

1/6"

3"

1/2"

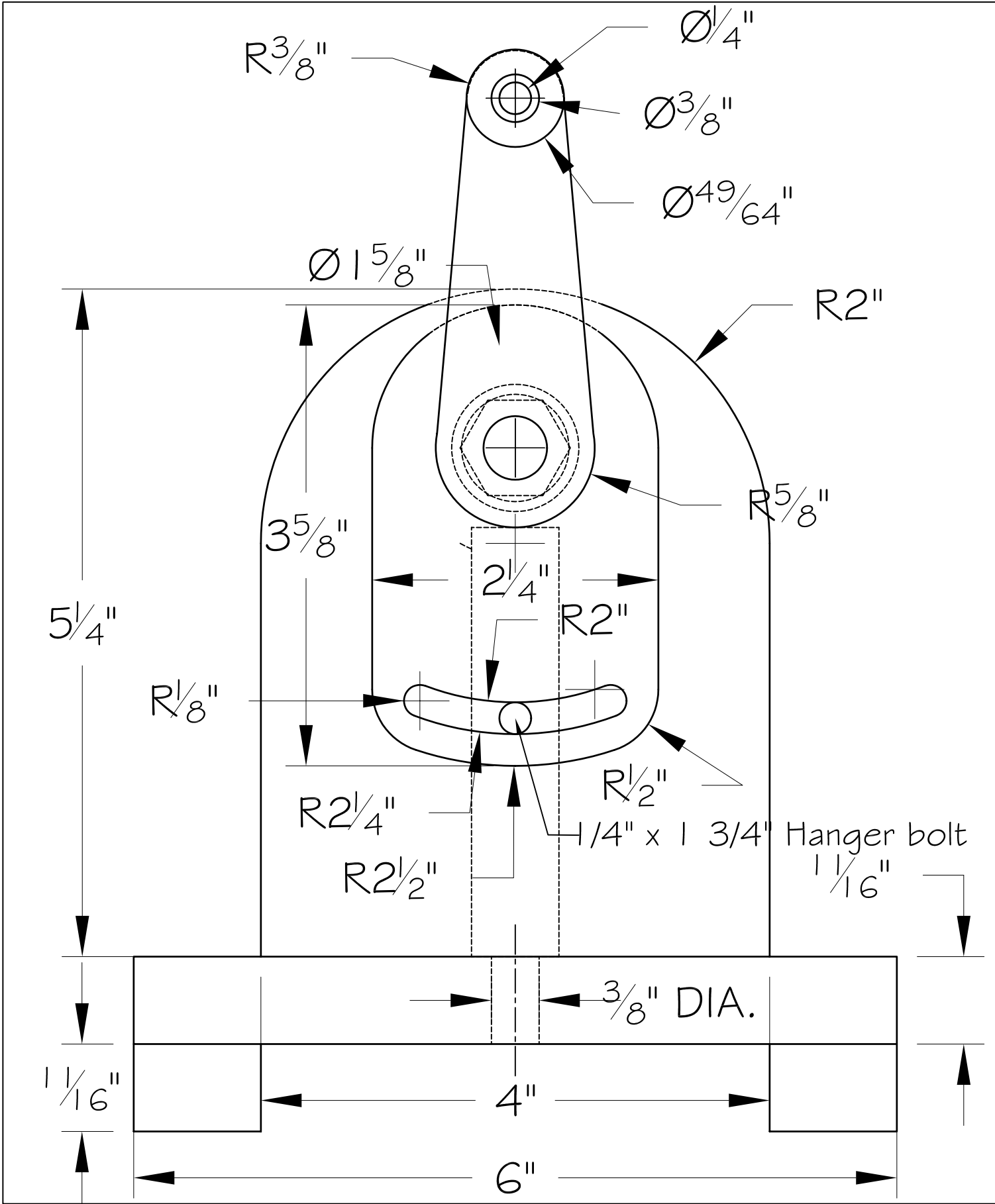

Jean Michel	TITRE threader feeder mount 11.dwg	DESSIN PAR DRAWN BY jm	ECHELLE SCALE 1" = 4"
	PROJ PROJECT Wood Threader for boxes	NO: wt001 DATE: 02-06-30	FEUILLE PAGE 1/6